

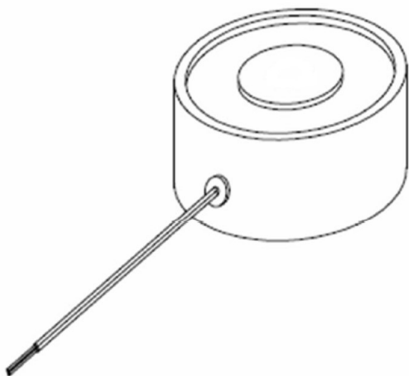

ELECTROMAGNET LEM-30P



TECHNICAL CHARACTERISTICS

Degree of protection: IP54

Rated Voltage: 24V DC

Power P (W): 2,8

Working Factor E.D.: 100%

Maintenance factor Fm (N): 220

Thermal Class: B (130)

Thickness of piece to hold: 3,5 mm